

Stage 1 H/DUTY BALL RACE THRUST BEARINGS & Elastomer Centers (STREET)

* Kit also provides up to 7 degrees Positive Caster same as 'M' Series

Also MANF. **STAGE 2** (STREET/RACE) and **STAGE 3** (FULL RACE) KITS. Plus Front lower inner arm 'extra' Camber & Caster performance bushings (For E36/46/Z3/Z4 models lower arm inner rear Mono ball / 2 Axis bushes - (also available in "offset" for extra positive Caster).

• Can fit (and adjust) with strut brace •

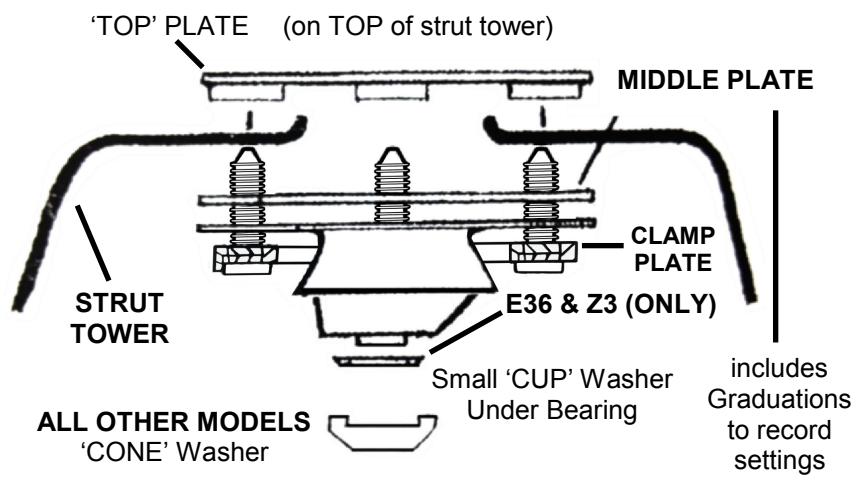

FITTING

Simply replaces original strut 'upper' mounts.

Refer manufacturers workshop manual re removal and installation
Observe all safety procedures

Thrust bearings are extra heavy duty - split outer ring - cageless for strength.

ALIGNING - NO NEED TO JACK TO ADJUST

- A. From Engine bay, loosen the '3' top mount nuts on strut tower.
- B. Use large screwdriver to lever / ratchet KMAC adjuster mount crossways for Camber (rear to increase positive caster).
- C. Once optimum setting obtained, tighten to **32Nm (23ft.lbs)**

INITIALLY SIT KMAC ADJUSTERS ON TOP OF STRUT TOWERS. . .

3 STRUT TOP HOLES ARE EVEN SPACING
Kit (Centers) are 'Left' and 'Right' hand offsets
THEREFORE BEFORE INSTALLING / ADJUSTING
(Select side & position that will achieve best results!)

E36, Z3, E81-93

E36 / Z3 'M' Series use stage 2 #191916-2L
stage 3 #191916-3L

A. IF OUTER TIRE WEAR
MOUNT POSITION FOR MORE
NEGATIVE CAMBER

This # A settings allows up to 7°s Positive Caster.

B. IF INNER TIRE WEAR
MOUNT POSITION FOR MAXIMUM
POSITIVE (+) CAMBER

C. FOR 'MAXIMUM' NEGATIVE
(-) CAMBER
(HOLE OFFSET FULLY INWARDS.)

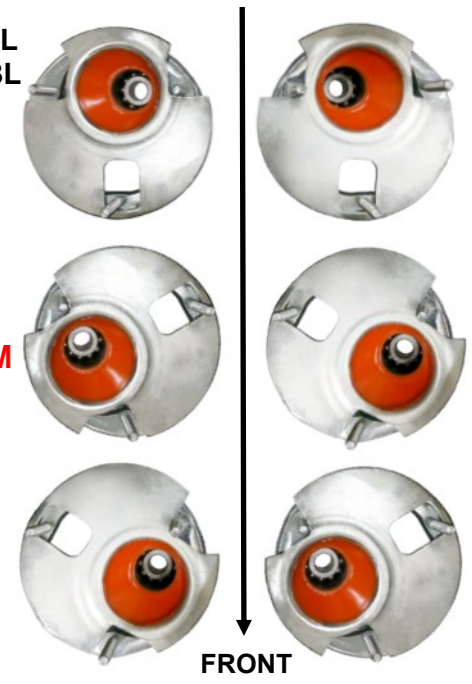

E39, E46, E60-64, Z4

• E46 / Z4 'M' Series USE - Stage 2 (Street/Race) #193616-2L
Stage 3 (Full Race) #193616-3L

Models - earth cable mount lug & micro filter box leg is on top of strut towers - detach the 3 alloy washers from under der
KMAC 'Top' plate (hold plate vertical & tap edge of washers). Discard Top plate and fit alloy washers only, under each mount nut.

Mount for more
Negative Camber

Mount for more
Positive Camber

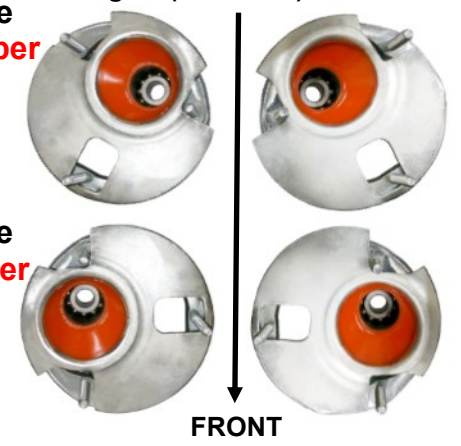

© KMAC Align 2020 #192416-1



Front #192416-1J Stage 1 (STREET)

FRONT CAMBER (and CASTER) FOR THE 1st TIME
(and accurate-underload direct on alignment rack)

- ✓ **Quickest Adjustment** - Change Camber & Caster settings - from engine bay and with strut brace fitted
- ✓ **Centers H/Duty** - Ball Race (Thrust Bearings for steering loads with elastomer for extended wear life)

ALSO MANUFACTURED
STAGE 2 (STREET / RACE), STAGE 3 (FULL RACE).
SEE WEB SITE

- **FRONT** - Also lower inner arm 'extra' Camber & Caster performance bushings - Mono ball / 2-axis design (E36/46/Z3/Z4 models lower arm rear mono ball bushes - also available in "offset" for extra positive Caster).

Always 1st With The Latest Design Breakthroughs

- 1. WISHBONE:** Precise Ball Joint Adjustment System.
- 2. STRUT(top):** Biggest/Quickest Adjustment System.
- 3. BUSHINGS:** Single Wrench - Precise On Car Adjustment.
Including unique KMAC "non-slip" lock system!

Actual Inventors/Patentee's - The '3' Basic Suspension Systems

We do appreciate any ideas to further improve our market leadership !